



# **LITEMAX PV0615E**

Sunlight readable 6.4" LED B/L LCD

(1st Edition 8/14/2007 )

All information is subject to change without notice.

Approved by	Checked by	Prepared by
David	Sharline	Eric

**LITEMAX Electronics Inc.**

8F-2, No.133, Lane 235, Bau-chiau Rd.,  
Shin-dian City, Taipei County, Taiwan R.O.C.

Tel : 886-2-8919-1858

Fax: 886-2-8919-1300

Homepage: <http://www.litemax.com.tw>

## Record of Revision

Version and Date	Page	Old Description	New Description	Remark

## Contents

---

Record of Revision .....	2
Contents .....	3
Application .....	4
Features .....	4
Mechanical Specifications .....	4
Input / Output Terminals .....	6
Absolute Maximum Ratings: .....	8
Electrical Characteristics .....	9
Recommended Operating Condition for backlight:.....	9
Input / Output signal timing chart.....	10
Display Time Range .....	11
Vertical Display Position .....	14
Display Color and Gray Scale Reference .....	15
Control Board Dip Switch Format.....	16
Power n Sequence .....	17
Optical Characteristics Specification: .....	18
Handling Cautions.....	21
Mounting of module .....	21
Precautions in mounting .....	21
Adjusting module .....	21
Others .....	21
Polarizer mark.....	21
Reliability Test .....	22
Block Diagram.....	23

## Application

---

This product applies computer peripheral , industrial meter , image communication and multi-media.

### Features

- Compatible with VGA-480 , VGA-400 , VGA-350 mode
- Support the DENB mode
- Pixel in stripe configuration
- Slim and compact
- Display Colors : 262,144 colors
- Image Reversion : Up/Down and Left/Right
- Active area / Outline area = 57.02 %
- Viewing Direction : 6 o'clock
- Backlight lamps are Replaceable

### Mechanical Specifications

Parameter	Specifications	Unit
Screen Size	6.4 (diagonal)	inch
Display Format	640xR, G, Bx480	dot
Active Area	129.6 (H)x97.4 (V)	mm
Dot Pitch	0.0675 (H)x0.203 (V)	mm
Pixel Pitch	0.2025 (H)x0.203 (V)	mm
Pixel Configuration	Stripe	
Outline Dimension	178.8(W)x126.8 (H)x20.4 (D) (Typ.)	mm
Weight	340±10	g

# Mechanical Drawing of TFT-LCD Module

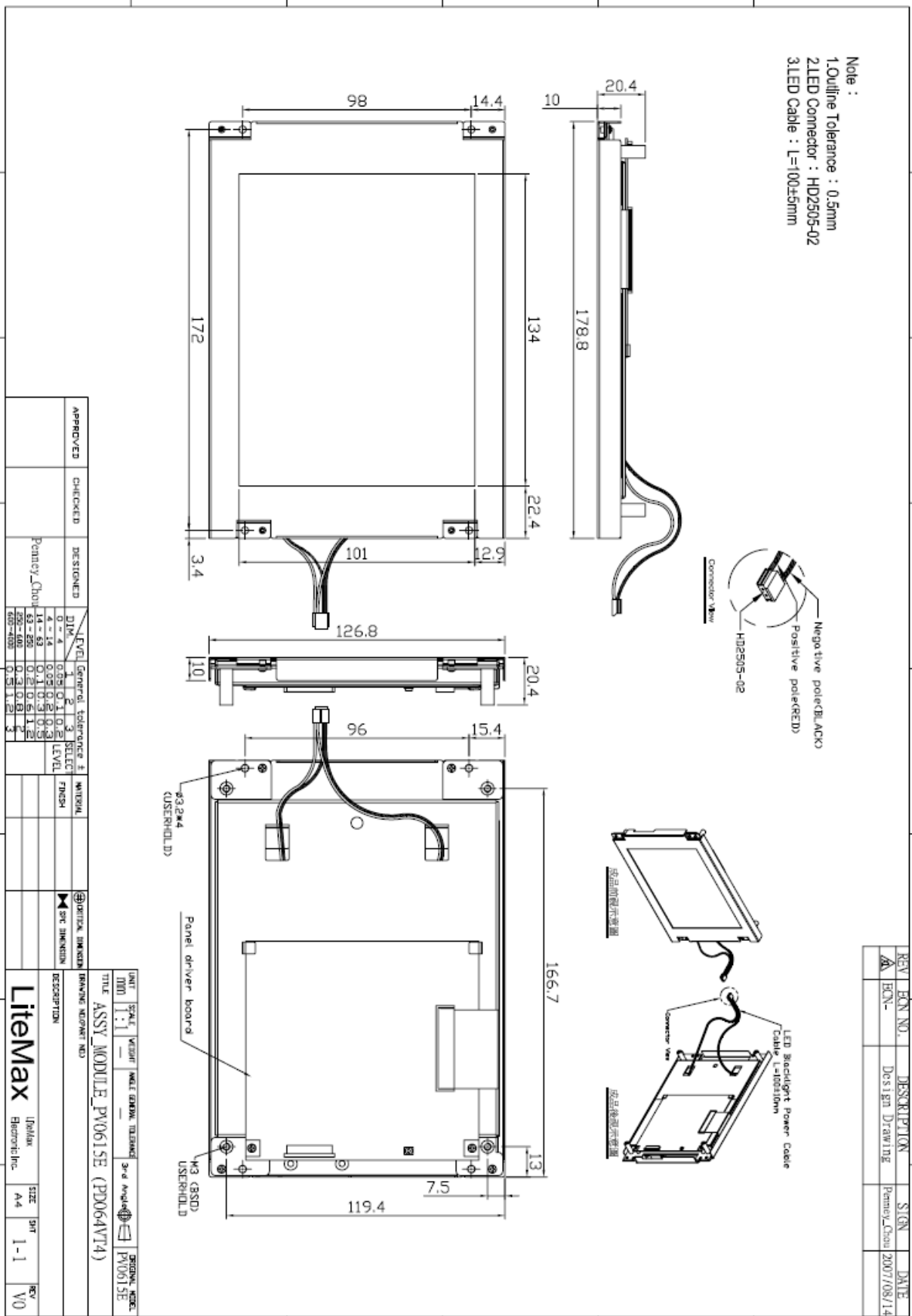

APPROVED	CHECKED	DESIGNED	LEVEL	General Tolerance	±	SELECT	FINISH	SPRINKLING
		Penny Chen	1	0.4	0.2	1		
			2	0.25	0.1	2		
			3	0.15	0.05	3		
			4	0.1	0.02	4		
			5	0.05	0.01	5		
			6	0.02	0.005	6		
			7	0.01	0.002	7		
			8	0.005	0.001	8		

REV	ECN NO.	DESCRIPTION	SIGN	DATE
1		Design Drawing	Penny Chen	2007/08/14

UNIT	SCALE	VISIB	MAKE	GENERAL TOLERANCE	3rd Angle	ORIGINAL MODEL
MM	1:1					PV0615E

TITLE: ASSY\_MODULE\_PV0615E (P0064VT4)

DESCRIPTION: INVAIVE SIGNART NO.

**LiteMax** | Ibelix | SIZE: A4 | 3rd: 1-1 | REV: V0

## Input / Output Terminals

TFT-LCD Panel Driving

LCD module connector (Reference)

JAE IL-FPR-30S-HF (Right angle Lower-side contact)

Pin No.	Symbol	Function	Remark
1	CLK	Clock Signal for Sampling Image Digital Data	
2	Hsync	Horizontal Synchronous Signal	Note (1)
3	Vsync	Vertical Synchronous Signal	
4	GND	Ground (0V)	
5	R0	Red Image Data Signal (LSB)	
6	R1	Red Image Data Signal	
7	R2	Red Image Data Signal	
8	R3	Red Image Data Signal	
9	R4	Red Image Data Signal	
10	R5	Red Image Data Signal (MSB)	
11	GND	Ground (0V)	
12	G0	Green Image Data Signal (LSB)	
13	G1	Green Image Data Signal	
14	G2	Green Image Data Signal	
15	G3	Green Image Data Signal	
16	G4	Green Image Data Signal	
17	G5	Green Image Data Signal (MSB)	
18	GND	Ground (0V)	
19	B0	Blue Image Data Signal (LSB)	
20	B1	Blue Image Data Signal	
21	B2	Blue Image Data Signal	
22	B3	Blue Image Data Signal	
23	B4	Blue Image Data Signal	
24	B5	Blue Image Data Signal (MSB)	
25	GND	Ground (0V)	
26	DENB	Enable	Note (1) Note (2)
27	VCC	DC +5.0V Power Supply	Note (3)
28	VCC	DC +5.0V Power Supply	
29	R/L	Horizontal Image Shift-direction Select Signal	Note (4)
30	U/D	Vertical Image Shift-direction Select Signal	Note (5)

Note (1) The relationship between DENB & SYNC. Mode

1. DENB mode with the top priority.
2. When working with the SYNC. Mode, the TFT-LCD module is compatible with three kinds of VGA timing . They are VGA-480 , VGA-400 and VGA-350 mode . The polarization of Hsync and Vsync determine the timings.

Mode SYNC.	DENB	VGA-480	VGA-400	VGA-350
Hsync Polarization	Don't care	Negative / Positive	Negative	Positive
Vsync Polarization	Don't care	Negative / Positive	Positive	Negative

Note (2) DENB input signal.

1. If customer wanted to off the DENB mode , you must keep the DENB (pin 27) always High or Low.

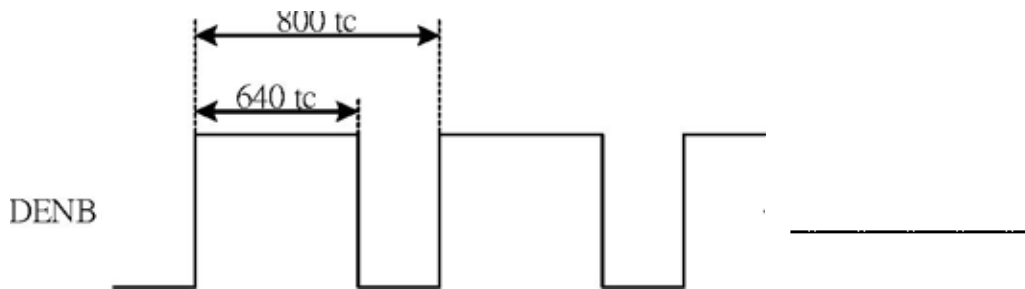

Note (3)  $V_{CC}$  TYP.=+5V

Note (4) (5) : The definitions of U/D & R/L

R/L(PIN 30)= High , U/D(PIN 31)= Low

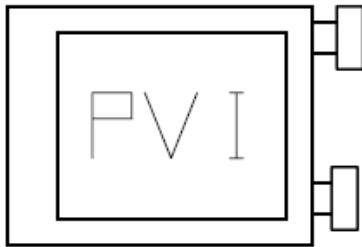

R/L(PIN 30)= Low , U/D(PIN 31)= High

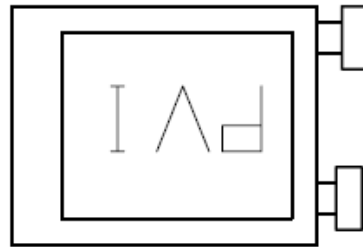

### Absolute Maximum Ratings:

---

The followings are maximum values , which if exceeded, may cause faulty operation or damage to the unit.  
GND=0V, Ta=25°C

Parameters	Symbol	MIN.	MAX.	Unit	Remark
+5V Supply Voltage	V <sub>cc</sub>	-0.3	+7.0	V	
Input Signals Voltage	V <sub>sig</sub>	-0.3	V <sub>cc</sub> +0.3	V	Note (1)
Storage Temperature	T <sub>stg</sub>	-30	+70	°C	
Operating Temperature	T <sub>opa</sub>	-20	+70	°C	Note (2)

Note (1) Input signals include CLK, Hsync , Vsync , DENB , R[0:5] , G[0:5] and B[0:5].

Note (2) Optical characteristics shown in Table 9-1 are measured under Ta=+25°C.

## Electrical Characteristics

Recommended Operating Condition for TFT-LCD panel : GND = 0V , Ta = 25<sup>°C</sup>

Parameters	Symbol	Min.	Typ.	Max.	Unit	Remark
+5V Supply Voltage	V <sub>CC</sub>	+4.75	+5.0	+5.25	V	
Supply Input Ripple Voltage	V <sub>CCRP</sub>			0.1	Vp-p	V <sub>CC</sub> =+5V
Input Signals Voltage (High)	V <sub>IH</sub>	+2.6			V	
Input Signals Voltage (Low)	V <sub>IL</sub>			+0.5	V	

### Recommended Operating Condition for backlight:

Ta = 25<sup>°C</sup>

Item	Symbol	Min.	Typ.	Max.	Unit	Remark
LED Current	I <sub>L</sub>	-	1.65	-	A	
LED Voltage	V <sub>L</sub>	-	6.5	-	Vrms	I <sub>L</sub> =1.65A

Backlight driving connector : HD2505-02 , Pin No. : 2 , Pitch : 2.54 mm

Pin No	Symbol	Description	Remark
1	+	Positive Pole(RED Cable)	
2	-	Negative Pole(Black Cable)	

Parameters	Symbol	Typ.	Max.	Unit	Remark
+5V Current Dissipation	I <sub>CC</sub>	100	120	mA	
LCD Panel Power Consumption		0.5	0.6	W	Note (1)
Backlight Power Consumption		10.73		W	Note (2)

Note (1) The power consumption of backlight is not included.

Note (2) Backlight lamp power consumption is calculated by I<sub>L</sub>×V<sub>L</sub>.

## Input / Output signal timing chart

Parameters		Symbol	Format	Min.	Typ.	Max.	Unit	Note	
CLK	Frequency	$F_c=1/T_c$	All	-	25.175	-	MHz	Note (1)	
		$t_c$	All	-	40	-	ns		
Hsync	Period	Hp	All	-	31.778	-	us		
				-	800	-	tc		
	Display period	Hd	All	-	640	-	tc		
	Pulse width	Hpw	All	12	96	139	tc		
	Back-porch	Hbp	All	12	48	139	tc		
	Front-porch	Hfp	All	-	16	-	tc		
	Hpw+Hbp			All	136	144	151	tc	
	Hsync-CLK	Hhc	All	10	-	$T_c-10$	ns		
Vsync-Hsync	Hvh	All	0	0	200	tc			
Vsync	Period	Vp	480	-	16.8	-	ms		
				515	525	800	Hp		
				400	-	14.3	-	ms	
					446	449	480	Hp	
				350	-	14.3	-	ms	
					447	449	510	Hp	
	Display period	Vdp	480	-	480	-	Hp		
				400	-	400		-	
				350	-	350		-	
	Pulse width	Vpw	All	2	2	35	Hp		
	Back-porch	Vbp	480	2	33	35	Hp		
				400	2	35		38	
				350	2	60		63	
	Front-porch	Vfp	480	1	10	-	Hp		
				400	1	12		-	
				350	1	37		-	
	Vpw+Vbp		480	31	35	38	Hp		
				400	33	37		40	
350				58	62	65			
Data	CLK-DATA	Dcd	All	10		-	ns		
	DATA-CLK	Ddc	All	10		-	ns		
DENB	Horizontal scanning period	T1	All	780	800	900	tc		
	Horizontal display period	T2	All	-	640	-	tc		
	Vertical display period	T3	All	-	480	-	T1		
	Frame cycling period	T4	All	515	525	800	T1		

Note (1)  $T_c$  is the period of sampling clock. In case of low-frequency, the image-flicker may occur.

## Display Time Range

### (1) Vertical Timing :

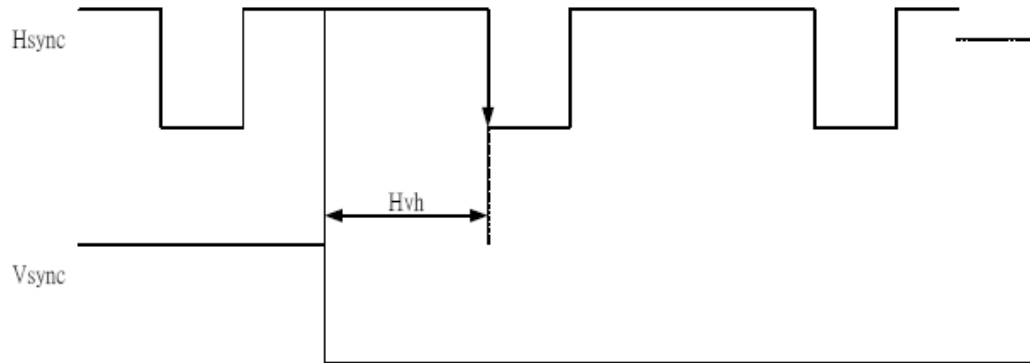

### (2) Horizontal Timing :

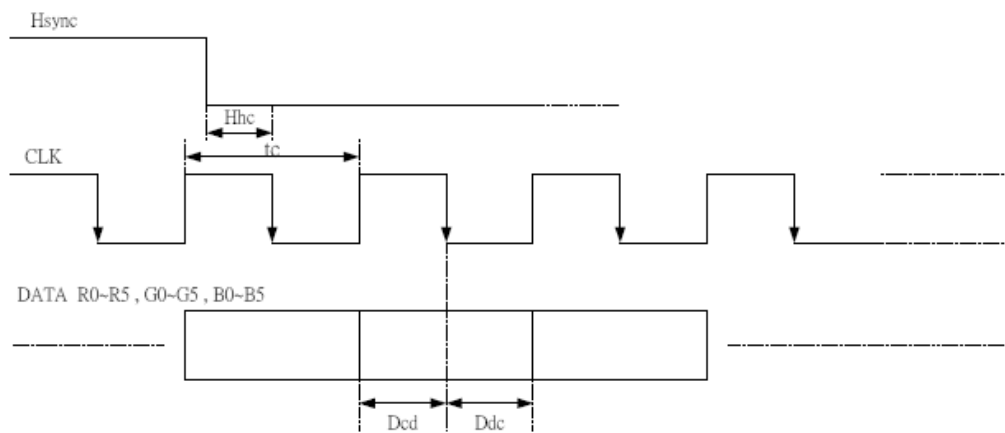

### (3) DENB Timing :

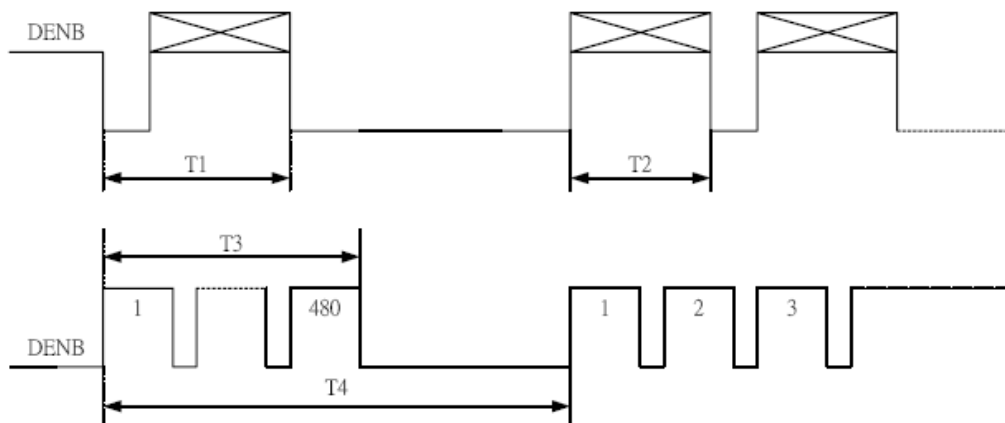

(4) Detail of Horizontal Timing :

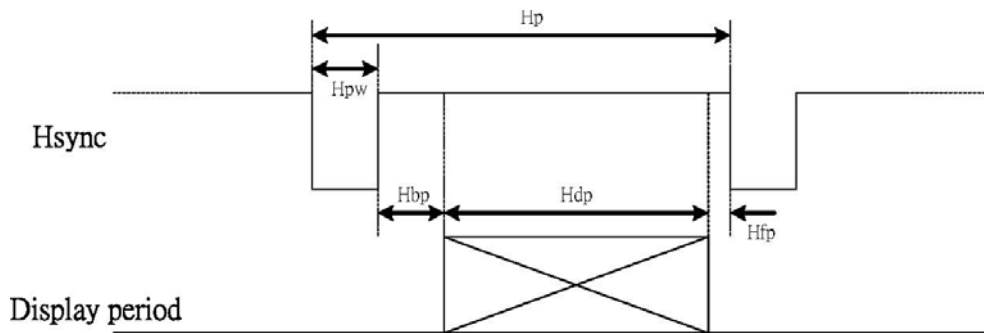

(a) VGA-480 Mode (Hsync = Positive / Negative Polarization)

Item	Description	Clock Cycles	Time
A	Horizontal Width	96	3.813 $\mu s$
B	Horizontal B-Porch	48	1.907 $\mu s$
C	Horizontal Display	640	25.422 $\mu s$
D	Horizontal F-Porch	16	0.636 $\mu s$
E	Horizontal Total	800	31.778 $\mu s$

(b) VGA-400 Mode (Hsync = Negative Polarization)

Item	Description	Clock Cycles	Time
A	Horizontal Width	96	3.813 $\mu s$
B	Horizontal B-Porch	48	1.907 $\mu s$
C	Horizontal Display	640	25.422 $\mu s$
D	Horizontal F-Porch	16	0.636 $\mu s$
E	Horizontal Total	800	31.778 $\mu s$

(c) VGA-350 Mode (Hsync = Positive Polarization)

Item	Description	Clock Cycles	Time
A	Horizontal Width	96	3.813 $\mu s$
B	Horizontal B-Porch	48	1.907 $\mu s$
C	Horizontal Display	640	25.422 $\mu s$
D	Horizontal F-Porch	16	0.636 $\mu s$
E	Horizontal Total	800	31.778 $\mu s$

(5) Detail of Vertical Timing :

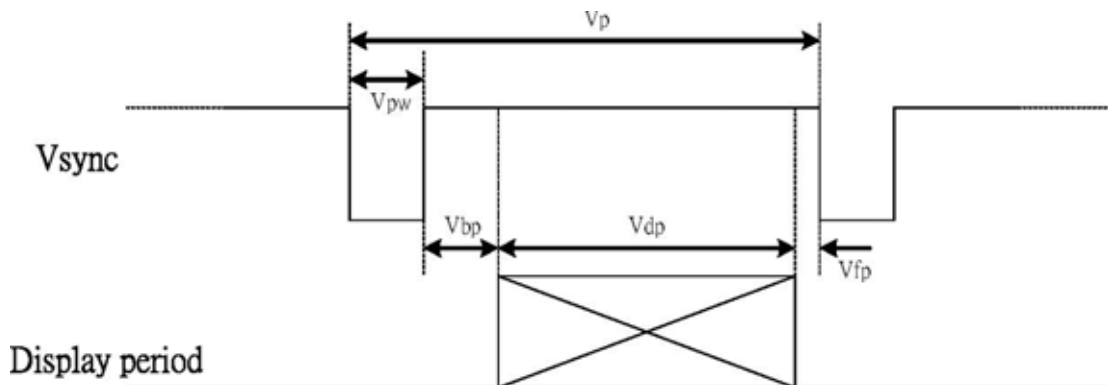

(a) VGA-480 Mode (Vsync = Positive / Negative Polarization)

Item	Description	Horizontal Lines	Time
A	Vertical Width	2	63.5 $\mu$ s
B	Vertical B-Porch	33	1.049 ms
C	Vertical Display	480	15.253 ms
D	Vertical F-Porch	10	317.8 $\mu$ s
E	Vertical Total	525	16.683 ms

(b) VGA-400 Mode (Vsync = Positive Polarization)

Item	Description	Horizontal Lines	Time
A	Vertical Width	2	63.5 $\mu$ s
B	Vertical B-Porch	35	1.112 ms
C	Vertical Display	400	12.711 ms
D	Vertical F-Porch	12	381.0 $\mu$ s
E	Vertical Total	449	14.268 ms

(c) VGA-350 Mode (Vsync = Negative Polarization)

Item	Description	Horizontal Lines	Time
A	Vertical Width	2	63.5 $\mu$ s
B	Vertical B-Porch	60	1.907 ms
C	Vertical Display	350	11.122 ms
D	Vertical F-Porch	37	1.176 $\mu$ s
E	Vertical Total	449	14.268 ms

## Vertical Display Position

Mode	Hsync	Vsync	V-Start Position	V-Display	Remark
VGA-480	Positive / Negative	Positive / Negative	34	480 lines	
VGA-400	Negative	Positive	17	400 lines	Note 8
VGA-350	Positive	Negative	30	350 lines	Note 9

Note (3) As the format is VGA-400 (Hsync = Negative , Vsync = Positive) , LCD module will adjust the display area to the center of display . At this time , both of the upper and lower display areas have 40 blanking lines (the display color is black) . The actual display area is center 400 lines .

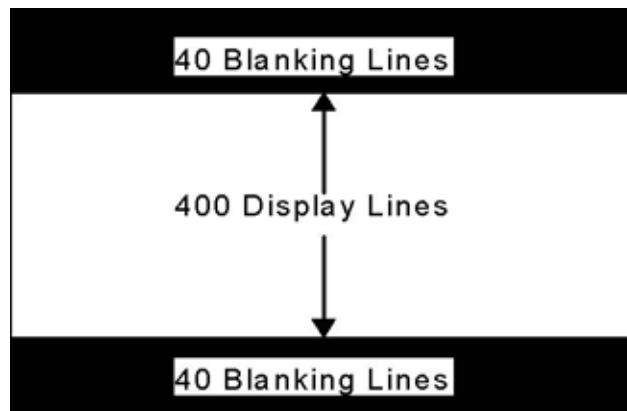

Note (4) As the format is VGA-350 (Hsync = Positive, Vsync = Negative) , LCD module will adjust the display area to the center of display . At this time , both of the upper and lower display areas have 65 blanking lines (the display color is black) . The actual display area is center 350 lines .

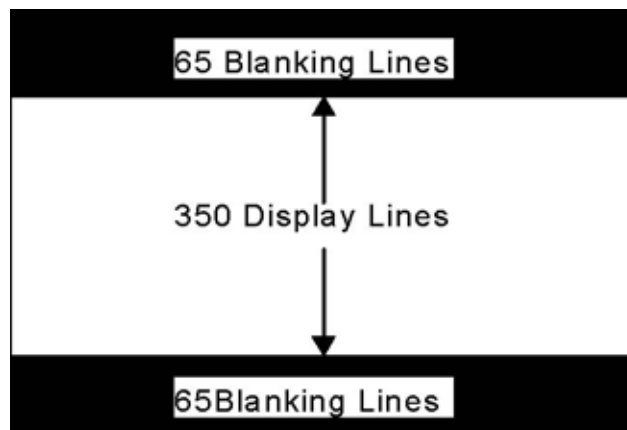

## Display Color and Gray Scale Reference

Color		Input Color Data																	
		Red						Green						Blue					
		R5	R4	R3	R2	R1	R0	G5	G4	G3	G2	G1	G0	B5	B4	B3	B2	B1	B0
Basic Colors	Black	0	0	0	0	0	0	0	0	0	0	0	0	0	0	0	0	0	0
	Red (63)	1	1	1	1	1	1	0	0	0	0	0	0	0	0	0	0	0	0
	Green (63)	0	0	0	0	0	0	1	1	1	1	1	1	0	0	0	0	0	0
	Blue (63)	0	0	0	0	0	0	0	0	0	0	0	0	1	1	1	1	1	1
	Cyan	0	0	0	0	0	0	1	1	1	1	1	1	1	1	1	1	1	1
	Magenta	1	1	1	1	1	1	0	0	0	0	0	0	1	1	1	1	1	1
	Yellow	1	1	1	1	1	1	1	1	1	1	1	1	0	0	0	0	0	0
	White	1	1	1	1	1	1	1	1	1	1	1	1	1	1	1	1	1	1
Red	Red (00)	0	0	0	0	0	0	0	0	0	0	0	0	0	0	0	0	0	0
	Red (01)	0	0	0	0	0	1	0	0	0	0	0	0	0	0	0	0	0	0
	Red (02)	0	0	0	0	1	0	0	0	0	0	0	0	0	0	0	0	0	0
	Darker																		
	↓	↓	↓	↓	↓	↓	↓	↓	↓	↓	↓	↓	↓	↓	↓	↓	↓	↓	↓
	Brighter																		
	Red (61)	1	1	1	1	0	1	0	0	0	0	0	0	0	0	0	0	0	0
	Red (62)	1	1	1	1	1	0	0	0	0	0	0	0	0	0	0	0	0	0
Red (63)	1	1	1	1	1	1	0	0	0	0	0	0	0	0	0	0	0	0	
Green	Green (00)	0	0	0	0	0	0	0	0	0	0	0	0	0	0	0	0	0	0
	Green (01)	0	0	0	0	0	0	0	0	0	0	0	1	0	0	0	0	0	0
	Green (02)	0	0	0	0	0	0	0	0	0	0	1	0	0	0	0	0	0	0
	Darker																		
	↓	↓	↓	↓	↓	↓	↓	↓	↓	↓	↓	↓	↓	↓	↓	↓	↓	↓	↓
	Brighter																		
	Green (61)	0	0	0	0	0	0	1	1	1	1	0	1	0	0	0	0	0	0
	Green (62)	0	0	0	0	0	0	1	1	1	1	1	0	0	0	0	0	0	0
Green (63)	0	0	0	0	0	0	1	1	1	1	1	1	0	0	0	0	0	0	
Blue	Blue (00)	0	0	0	0	0	0	0	0	0	0	0	0	0	0	0	0	0	0
	Blue (01)	0	0	0	0	0	0	0	0	0	0	0	0	0	0	0	0	0	1
	Blue (02)	0	0	0	0	0	0	0	0	0	0	0	0	0	0	0	0	1	0
	Darker																		
	↓	↓	↓	↓	↓	↓	↓	↓	↓	↓	↓	↓	↓	↓	↓	↓	↓	↓	↓
	Brighter																		
	Blue (61)	0	0	0	0	0	0	0	0	0	0	0	0	1	1	1	1	0	1
	Blue (62)	0	0	0	0	0	0	0	0	0	0	0	0	1	1	1	1	1	0
Blue (63)	0	0	0	0	0	0	0	0	0	0	0	0	1	1	1	1	1	1	

## Control Board Dip Switch Format

### SW1

Item	Symbol	Condition	Remark
SW 1-1	-	No connection	Default (OFF)
SW 1-2	HP3	Horizontal Shift (8 Line)	Default (ON)
SW 1-3	HP2	Horizontal Shift (4 Line)	Default (OFF)
SW 1-4	HP1	Horizontal Shift (2 Line)	Default (OFF)
SW 1-5	HP0	Horizontal Shift (1 Line)	Default (ON)
SW 1-6	VP2	Vertical Shift (4 Line)	Default (OFF)
SW 1-7	VP1	Vertical Shift (2 Line)	Default (ON)
SW 1-8	VP0	Vertical Shift (1Line)	Default (ON)

1. The default state is base on SYNC. mode (VGA-480)
2. Total horizontal shift line are 15 lines (HP0~HP3 on)  
Total vertical shift line are 7 lines (VP0~VP2 on)

### SW2

Item	Symbol	Condition	Remark
SW 2-1	UD	Vertical Image Shift-direction Select	Default (ON)
SW 2-2	RL	Horizontal Image Shift-direction Select	Default (ON)

## Power n Sequence

---

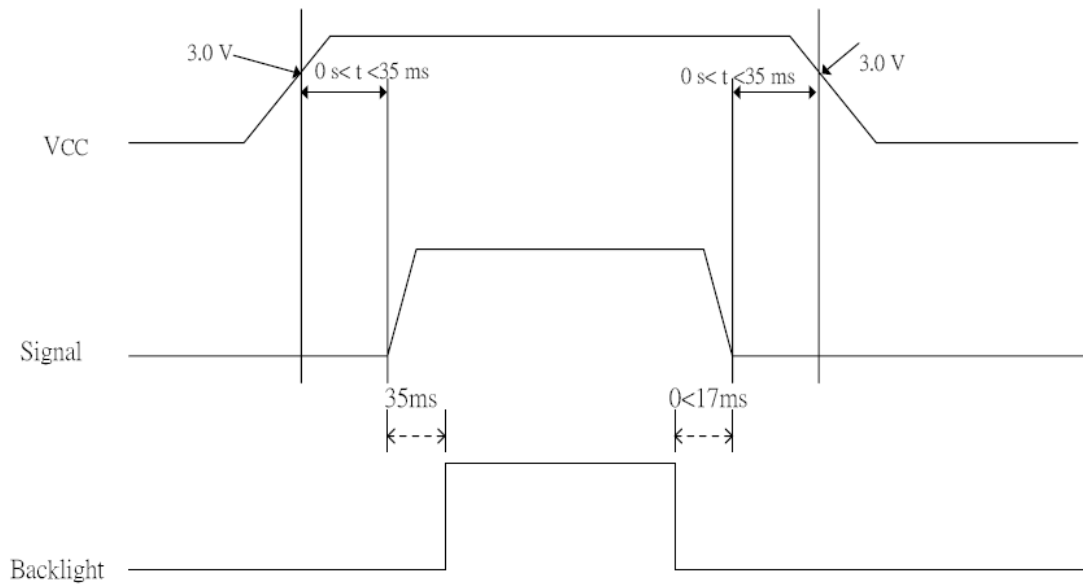

1. The supply voltage for input signals should be same as Vcc.
2. When the power is off , please keep whole signals (Hsync, Vsync, CLK, Data) low level or high impedance

## Optical Characteristics Specification:

Ta=25°C

Parameter		Symbol	Condition	MIN.	TYP.	MAX.	Unit	Remarks
Viewing Angle	Horizontal	$\theta_{21}$ , $\theta_{22}$	CR > 10	-	±60	-	deg	Note 9-1
	Vertical	$\theta_{12}$		-	40	-	deg	
		$\theta_{11}$		-	55	-	deg	
Contrast Ratio		CR	At optimized Viewing angle	-	400	-	-	Note 9-2
Response time	Rise	Tr	$\theta = 0^\circ$	-	15	30	ms	Note 9-4
	Fall	Tf		-	25	50	ms	
Brightness			$\theta = 0^\circ$	-	1000	-	cd/m <sup>2</sup>	Note 9-3
Uniformity		U		-	80	-	%	Note 9-5
Cross Talk			$\theta = 0^\circ$	-	-	3	%	Note 9-6
White Chromaticity		x	$\theta = 0^\circ$	0.264	0.294	0.324	-	Note 9-3
		y		0.278	0.308	0.338	-	
Lamp Life Time				-	50,000	-	hr	

Note (1) The definitions of viewing angle diagrams :

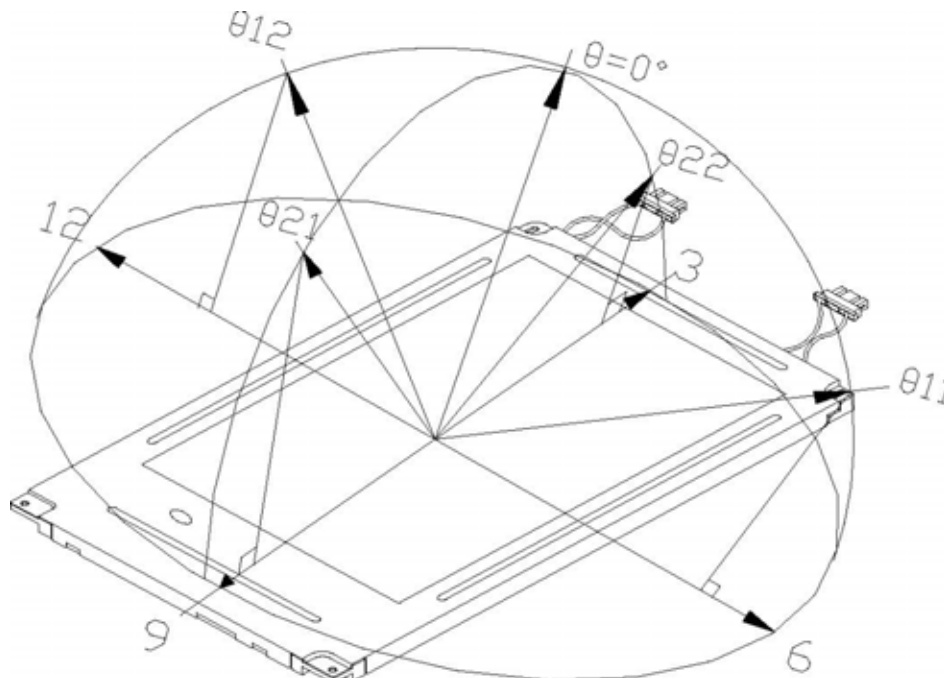

Note (2)

$$CR = \frac{\text{Luminance when LCD is White}}{\text{Luminance when LCD is Black}}$$

Contrast Ratio is measured in optimum common electrode voltage.

- Note (3)
1. Topcon BM-7 (fast) luminance meter 1° field of view is used in the testing ( after 20~30 minutes operation).
  2. Lamp current : 6 mA
  3. Inverter model : TDK-347.

Note (4) The definitions of response time

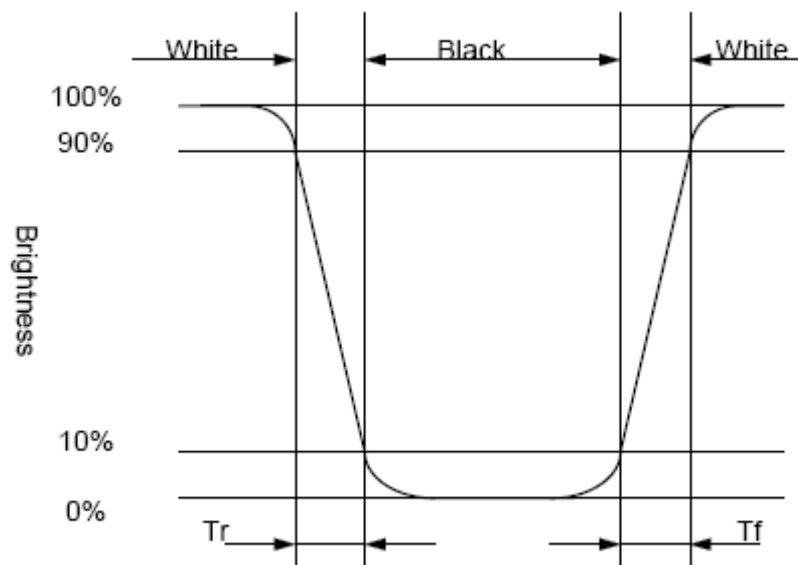

Note (5) The uniformity of LCD is defined as

$$U = \frac{\text{The Minimum Brightness of the 9 testing Points}}{\text{The Maximum Brightness of the 9 testing Points}}$$

Luminance meter : BM-5A or BM-7 fast (TOPCON)

Measurement distance : 500 mm +/- 50 mm

Ambient illumination : < 1 Lux Measuring direction : Perpendicular to the surface of module

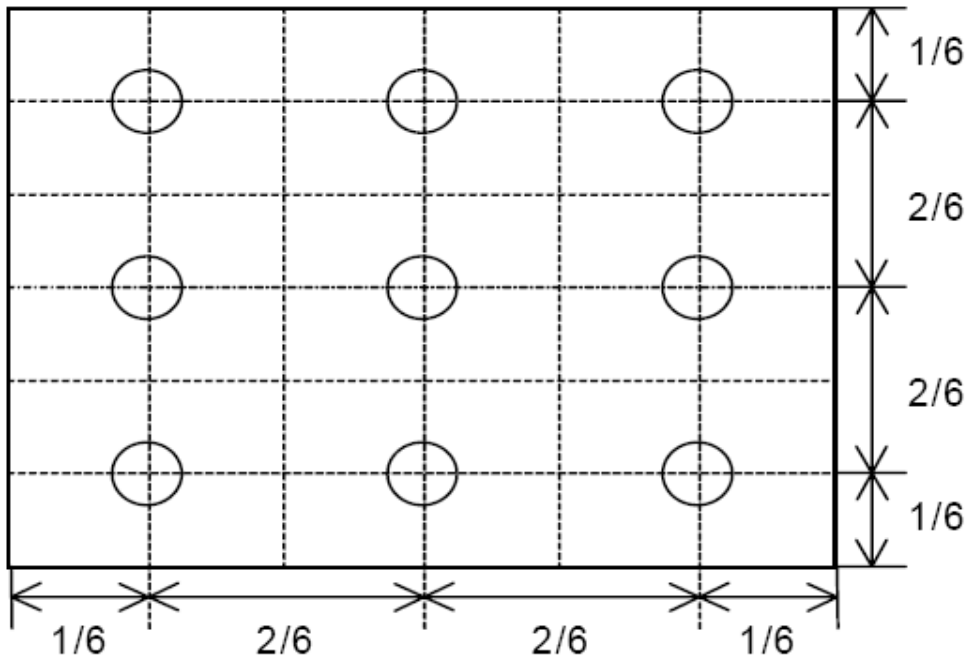

Note (6) Cross Talk (CTK) =  $\frac{YA - YB}{YA} \times 100\%$

YA : Brightness of Pattern A  
 YB : Brightness of Pattern B

Pattern A  
 (Gray Level 31)

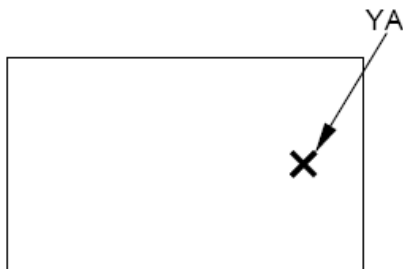

Pattern B  
 (Gray Level 31, central black box exclusive)

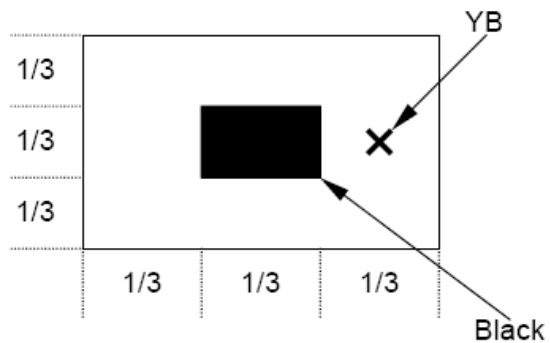

X: Testing Point (A and B are at the same point.)

(Gray Level 0)

## Handling Cautions

---

### Mounting of module

- a) Please power off the module when you connect the input/output connector.
- b) Please connect the ground pattern of the inverter circuit surely. If the connection is not perfect, some following problems may happen possibly.
  - 1.The noise from the backlight unit will increase.
  - 2.The output from inverter circuit will be unstable.
  - 3.In some cases a part of module will heat.
- c) Polarizer which is made of soft material and susceptible to flaw must be handled carefully.
- d) Protective film (Laminator) is applied on surface to protect it against scratches and dirt. It is recommended to peel off the laminator before use and taking care of static electricity.

### Precautions in mounting

- a) When metal part of the TFT-LCD module (shielding lid and rear case) is soiled, wipe it with soft dry cloth.
- b) Wipe off water drops or finger grease immediately. Long contact with water may cause discoloration or spots.
- c) TFT-LCD module uses glass which breaks or cracks easily if dropped or bumped on hard surface. Please handle with care. d) Since CMOS LSI is used in the module. So take care of static electricity and earth yourself when handling.

### Adjusting module

- a) Adjusting volumes on the rear face of the module have been set optimally before shipment.
- b) Therefore, do not change any adjusted values. If adjusted values are changed, the Specifications described may not be satisfied.

### Others

- a) Do not expose the module to direct sunlight or intensive ultraviolet rays for many hours.
- b) Store the module at a room temperature place.
- c) The voltage of beginning electric discharge may over the normal voltage because of leakage current from approach conductor by to draw lump read lead line around.
- d) If LCD panel breaks, it is possibly that the liquid crystal escapes from the panel. Avoid putting it into eyes or mouth. When liquid crystal sticks on hands, clothes or feet. Wash it out immediately with soap.
- e) Observe all other precautionary requirements in handling general electronic components. f) Please adjust the voltage of common electrode as material of attachment by 1 module.

### Polarizer mark

The polarizer mark is to describe the direction of wide view angle film how to mach up with the rubbing direction.

## Reliability Test

No	Test Item	Test Condition
1	Low Temperature Storage Test	Ta = -30 °C, 240 hrs
2	High Temperature Operation Test	Ta = +70 °C, 240 hrs
3	Low Temperature Operation Test	Ta = -20 °C, 240 hrs
4	High Temperature & High Humidity Operation Test	Ta = +60 °C, 90%RH, 240 hrs
5	Thermal Cycling Test (non-operating)	-25°C → +70°C, 200 Cycles      30 min    30 min
6	Vibration Test (non-operating)	2 Frequency : 10 ~ 57 Hz/Vibration Width :0.075mm 58-500 H/ / Gravity :9.8m/s Sweep time: 11 minutes Test period: 3 hrs for each direction of X, Y, Z
7	Shock Test (non-operating)	Gravity :490m/s Direction: ±X, ±Y, ±Z Pulse Width :11ms, half sine wave
8	Electrostatic Discharge Test (non-operating)	2150pF, 330Ω Air : ±15KV ; Contact : ±8KV 10 times/point , 9 points/panel face

Ta: ambient temperature

Note : The protective film must be removed before temperature test.

[Judgement Criteria]

Under the display quality test conditions with normal operation state , there should be no change which may affect practical display function.

## Block Diagram

