



LITEMAX AU1954

Sunlight Readable 19" LED B/L LCD

(1st Edition 6/6/2008)

All information is subject to change without notice.

Approved by	Checked by	Prepared by
David	Sharline	Eric

LITEMAX Electronics Inc.

8F-2, No.133, Lane 235, Bau-chiau Rd.,
Shin-dian City, Taipei County, Taiwan R.O.C.

Tel : 886-2-8919-1858

Fax: 886-2-8919-1300

Homepage: <http://www.litemax.com.tw>

Record Revision

Version and Date	Page	Old Description	New Description	Remark

Contents

Record Revision	2
Contents	3
Handling Precautions	4
General Description	5
Display Characteristics	5
Optical Characteristics	6
Optical Test	6
Test Mode :	7
Functional Block Diagram	9
Absolute Maximum Ratings	10
Absolute Ratings of TFT LCD Module	10
Absolute Ratings of Backlight Unit	10
Absolute Ratings of Environment	10
Electrical Characteristics	11
TFT LCD Module	11
Pixel Format Image	12
The Input Data Format	13
Signal Description	14
Interface Timing	15
Power ON/OFF Sequence	17
Connector & Pin Assignment	18
TFT LCD Module	18

Handling Precautions

- 1) Since front polarizer is easily damaged, be extremely careful when handling panel.
- 2) Be sure to turn off power supply when inserting or disconnecting from input connectors.
- 3) Wipe off water immediately. Long contact with water may cause discoloration or spots.
- 4) When the panel surface is soiled, wipe it with absorbent cotton or other soft cloth.
- 5) Since the panel is made of glass, it may break or crack if dropped or bumped on a hard surface.
- 6) Since CMOS LSI is used in this module, be careful of static electricity by grounding those handling the display.
- 7) Do not open nor modify the module assembly.
- 8) Do not press or touch the panel surface with hands or tools.
- 9) Do not press or move the reflector sheet at the back of the module in any direction.
- 10) **At the insertion or removal of the signal Interface Connector, be sure not to rotate nor tilt the interface connector of the TFT module.
- 11) After installation of the TFT module into an enclosure (Desktop monitor Bezel, for example), do not twist nor bend the TFT Module even momentarily. Design the enclosure so that no bending/twisting forces are applied to the TFT module. Otherwise the TFT module may be damaged.

General Description

AU1954 is a Color Active Matrix Liquid Crystal Display composed of a TFT-LCD panel, a driver circuit, and a backlight system. The screen format is intended to support the SXGA (1280(H) x 1024(V)) screen and 16.7M colors (RGB 6-bits + HiFRC data). All input signals are LVDS interface compatible. Inverter card of backlight is not included. AU1954 is designed for a display unit of outdoor display.

Display Characteristics

The following items are characteristics summary on the table under 25 °C condition:

Items	Unit	Specifications
Screen Diagonal	[mm]	482.6 (19.0")
Active Area	[mm]	376.32 (H) x 301.06 (V)
Pixels H x V		1280(x3) x 1024
Pixel Pitch	[mm]	0.294 (per one triad) x 0.294
Pixel Arrangement		R.G.B. Vertical Stripe
Display Mode		Normally White
White Luminance	[cd/m ²]	1000 (center, Typ)
Contrast Ratio		900 : 1 (Typ)
Optical ResponseTime	[msec]	5 ms(Typ, on/off)
Nominal Input Voltage VDD	[Volt]	+5.0 V
Power Consumption	[Watt]	36.11W (Typ) (PDD=5.11W, PBL=31 W)
Weight	[Grams]	2100
Physical Size (H x V x D)	[mm]	396 (H) x 324 (V) x 16.3(D) (Typ)
Electrical Interface		Dual channel LVDS
Surface Treatment		Hard-coating (3H), Non-Glare treatment
Support Color		16.2M colors (RGB 6-bit data + HiFRC data)
Temperature Range Operating Storage (Non-Operating)	[°C] [°C]	0 to +50 -20 to +60
RoHS Compliance		RoHS Compliance

Optical Characteristics

The optical characteristics are measured under stable conditions at 25°C
(Room Temperature):

Optical Test

Test Conditions

Room Temperature	25°C	R. Humidity	50±10%
Room Luminance	10nits		
Surveying Instruments	TOPCON BM-7 ; KLEIN K-10		

Panel

Model No	M190EG02	Version	V4
Brightness	100% (R:100 %,G:100 %,B100 %)	Contrast	100%
Power Consumption	5.11W(Typ.)	A/D Board	AD5621GA
Input Voltage	5V(Typ.)	Input Current	1.02A(Typ.)

Backlight

CCFL or LED	LED 96 PCS		
Inverter	LID19A01	Frequency	None
Input Voltage	17.8V	Input Current	1.73A
Power Consumption	31W	Time	30 minute

Test Data

Item	Symbol	Condition	Data	Unit	Note
Color chromaticity	Red	Rx	0.6337	-	Test Mode : (1) (2) (3)
		Ry	0.3535	-	
	Green	Gx	0.3292	-	
		Gy	0.5958	-	
	Blue	Bx	0.1437	-	
		By	0.0565	-	
	White	Wx	0.2906	-	
		Wy	0.3046	-	
Center Luminance of White	Lc	$\theta_x=0$ $\theta_y=0$ BM-7	1015	cd/ m ²	
Average	La		994	cd/ m ²	
Uniform	Lu		78	%	
Contrast Ratio	CR	$\theta_x=0$ $\theta_y=0$ Klein K-10	900	-	Test Mode : (1) (4)
Color Saturation	NTSC		75	%	
Viewing Angle	Horizontal	θ_{x+}	80	Deg	Test Mode : (1) (3)
		θ_{x-}	80		
	Vertical	θ_{y+}	80		
		θ_{y-}	80		

Reliability

Item	fill the bill	Note
Storage Temperature	Max : 60 °C Time : 24 hours Min : -20 °C Time : 24 hours	Test Mode : (5)
Operating Temperature	Max : 50 °C Time : 24 hours Min : 0 °C Time : 24 hours	
High Temperature & Humidity	50 °C , RH 80 % , 24 hours	
Thermal Shock	0 °C , 0.5 hour to 50 °C , 0.5 hour 100 cycle , 1 hour/cycle	
Life	-----°C-----hours	Test Mode (6)
Vibration	1.5 G , 10-200-10 Hz , 30 Min each Axis (X,Y,Z)	Test Mode : (7)

Shock (white carton)	50 G , 20 ms , Half-sine wave (X,Y,Z)	Test Mode : (7)
Drop (white carton)	Height: 60 cm 1corner,3edges,6surfaces (ASTMD4169-I)	

Test Mode :

Note (1) Definition of Viewing Angle (θ_x , θ_y) :

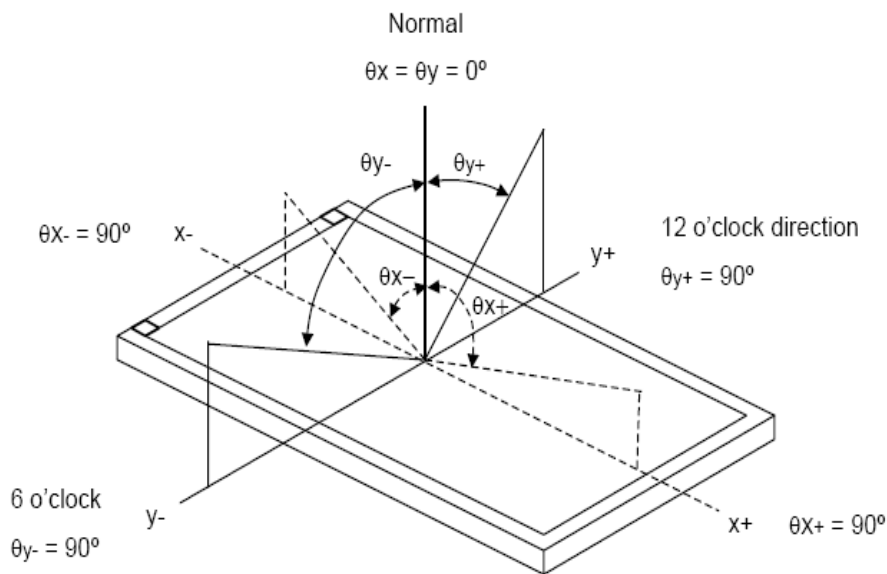

Note (2) Definition of Test Point :

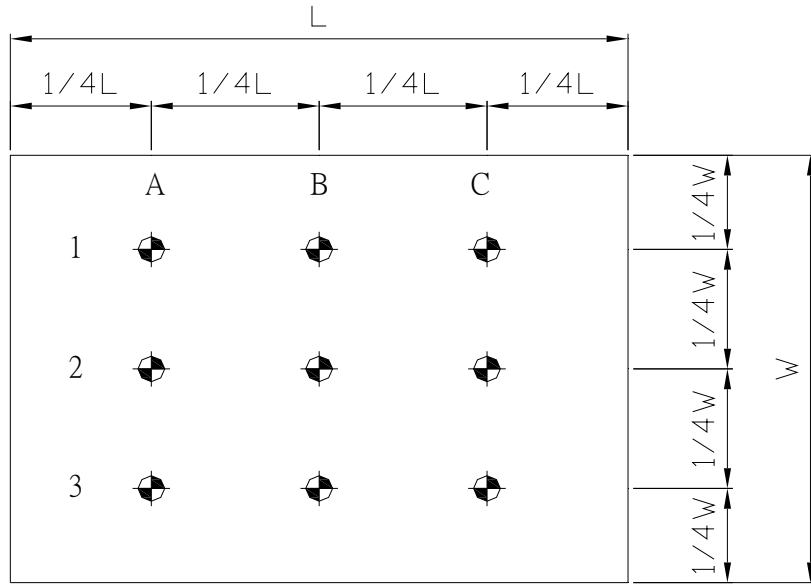

Active Area

Note (3) BM-7 Measurement Setup:

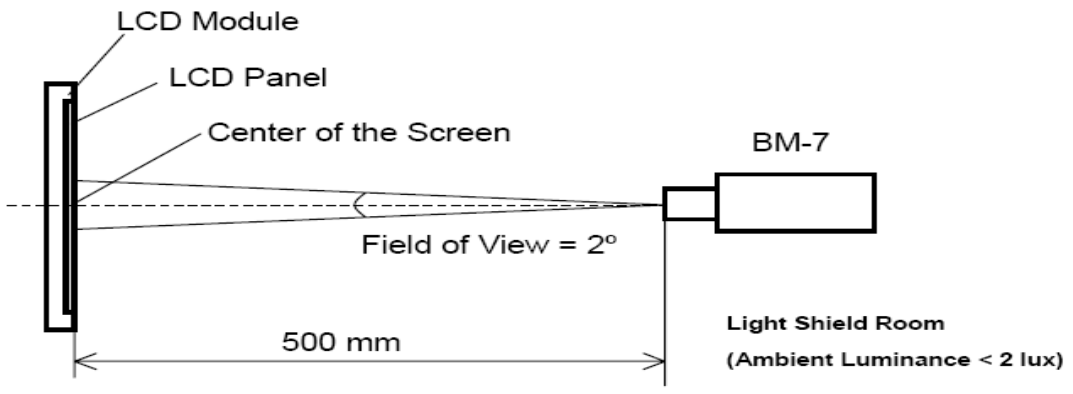

Note (4) Klein K-10 Measurement Setup:

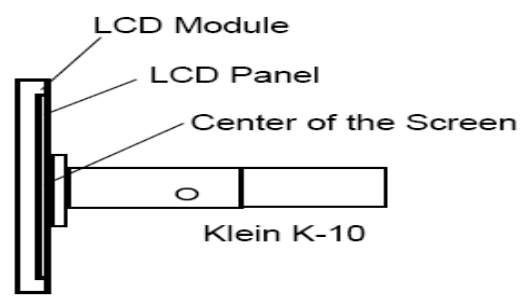

Functional Block Diagram

The following diagram shows the functional block of the 19.0 inches Color TFT-LCD Module:

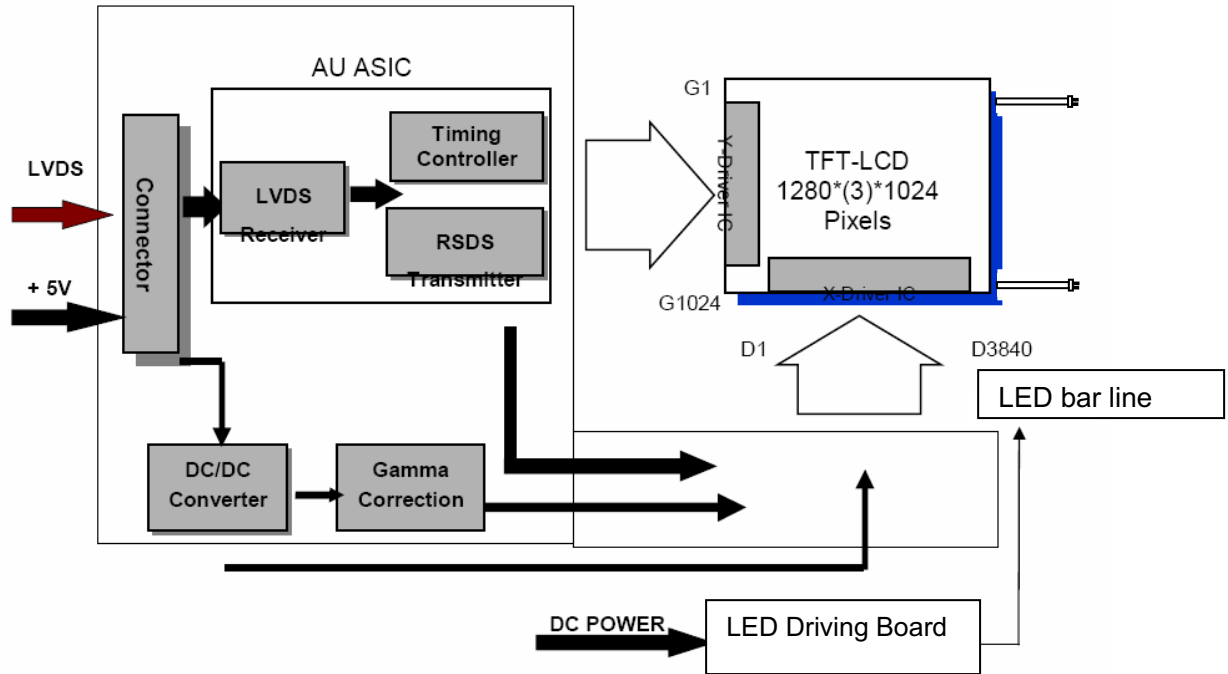

Absolute Maximum Ratings

Absolute maximum ratings of the module are as following:

Absolute Ratings of TFT LCD Module

Item	Symbol	Min.	Max.	Unit	Conditions
Logic/LCD Drive Voltage	VDD	-0.3	+6	[Volt]	Note 1, 2

Absolute Ratings of Backlight Unit

Item	Symbol	Min	Max	Unit	Conditions
LED Light bar Current	ILED	-	865	[mA] rms	Note 1,2

Absolute Ratings of Environment

Item	Symbol	Min.	Max.	Unit	Conditions
Operating Temperature	TOP	0	+50	[°C]	Note 3
Operation Humidity	HOP	5	90	[%RH]	
Storage Temperature	TST	-20	+60	[°C]	
Storage Humidity	HST	5	90	[%RH]	

Note 1: With in $T_a = 25^\circ\text{C}$

Note 2: Permanent damage to the device may occur if exceed maximum values

Note 3: For quality performance, please refer to AUO IIS (Incoming Inspection Standard).

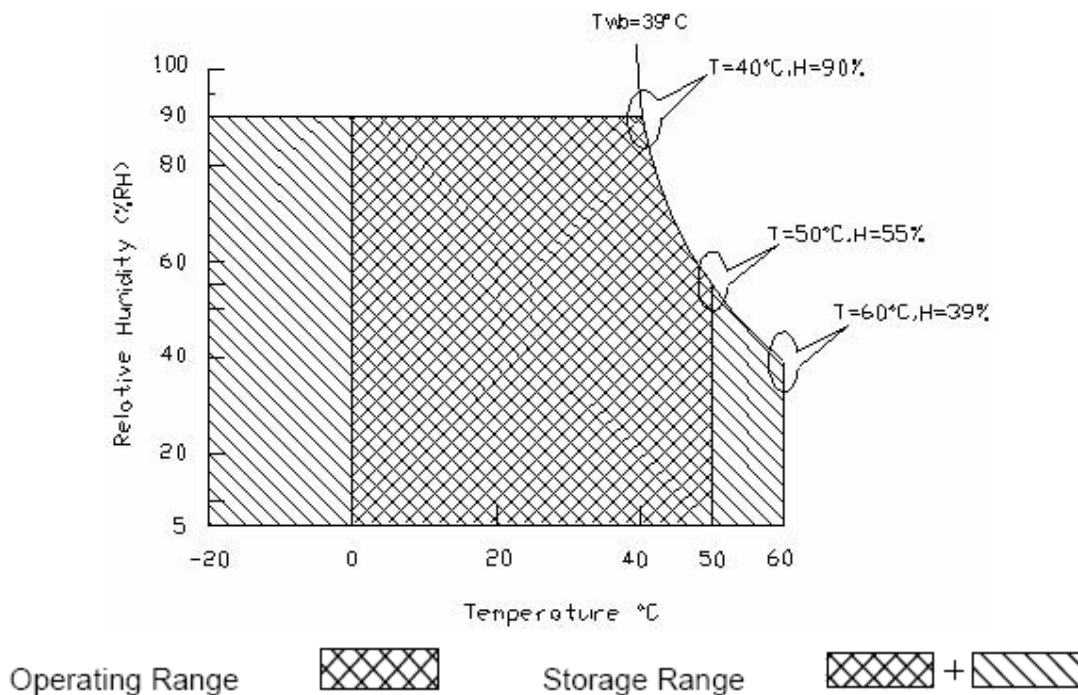

Electrical Characteristics

TFT LCD Module

Power Specification

Input power specifications are as follows:

Symble	Parameter	Min.	Typ.	Max.	Unit	Condition
VDD	Logic/LCD Drive Voltage	4.5	5.0	5.5	[Volt]	± 10%
IDD	Input Current	-	1.02	1.34	[A]	VDD= 5.0V, All Black Pattern At 75Hz, +30%
PDD	VDD Power	-	5.11	6.71	[Watt]	VDD= 5.0V, All Black Pattern At 75Hz , Note 1
IRush	Inrush Current	-	-	2.5	[A]	Note 2
VDDrp	Allowable Logic/LCD Drive Ripple Voltage	-	-	100	[mV] p-p	VDD= 5.0V, All Black Pattern At 75Hz

Note 1: The variance of VDD power consumption is ±30%.

Note 2: Measurement conditions:

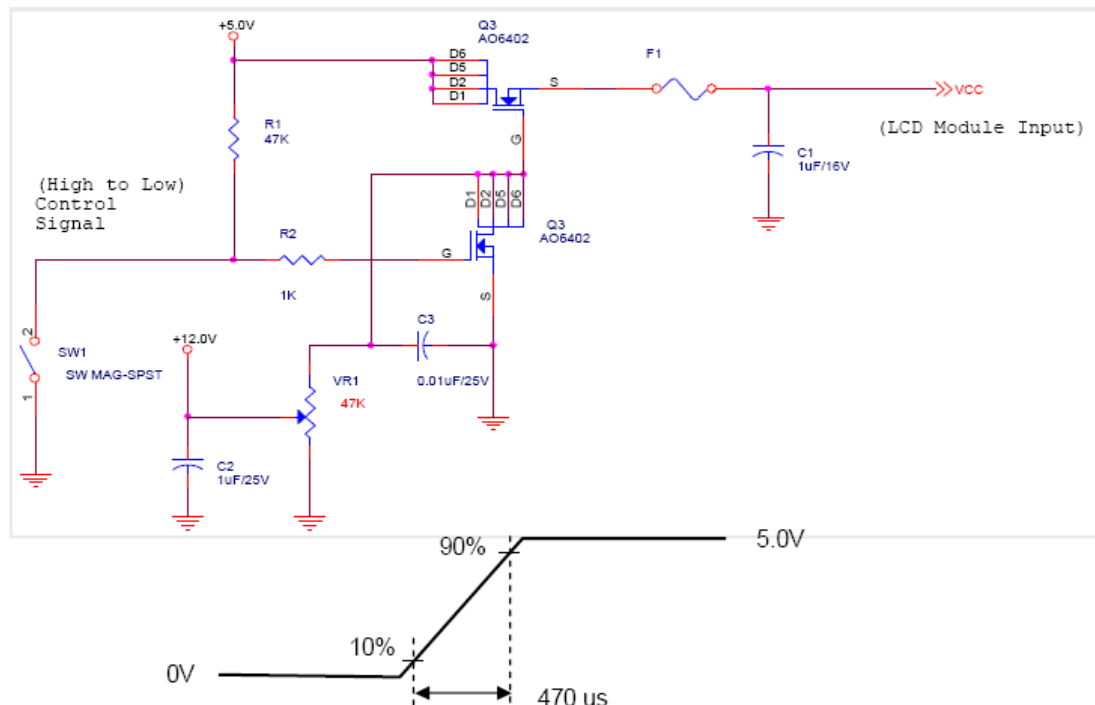

The Input Data Format

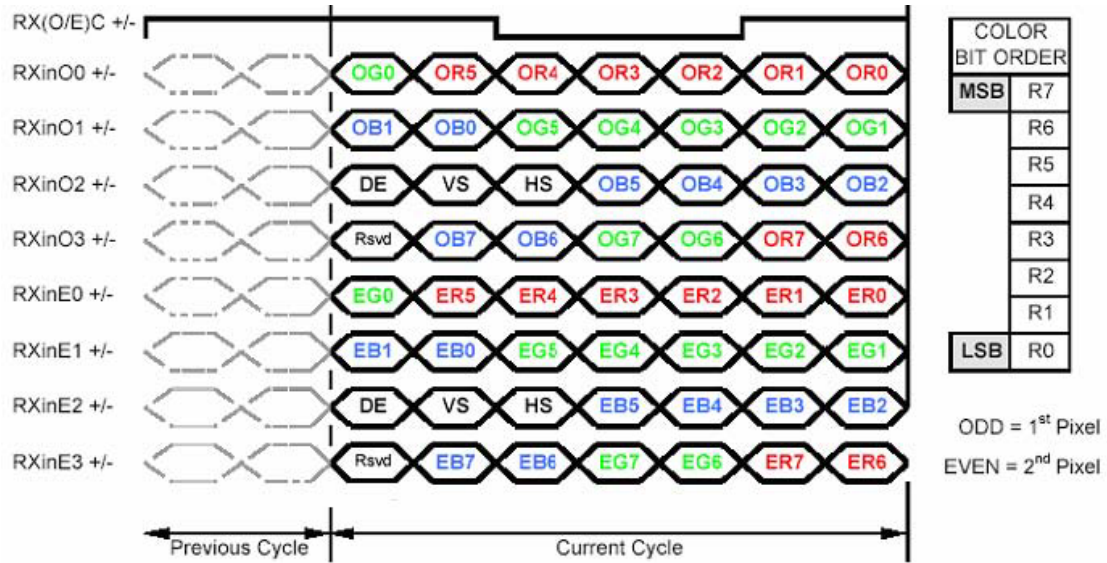

Note1: Normally, DE, VS, HS on EVEN channel is not used.

Note2: Please follow PSWG.

Note3: 8-bit in

Signal Description

The module using a pair of LVDS receiver SN75LVDS82(Texas Instruments) or compatible. LVDS is a differential signal technology for LCD interface and high speed data transfer device. Transmitter shall be SN75LVDS83(negative edge sampling) or compatible. The first LVDS port(RxOxxx) transmits odd pixels while the second LVDS port(RxExxx) transmits even pixels.

PIN #	SIGNAL NAME	DESCRIPTION
1	RxOIN0	Negative LVDS differential data input (Odd data)
2	RxOIN0+	Positive LVDS differential data input (Odd data)
3	RxOIN1	Negative LVDS differential data input (Odd data)
4	RxOIN1+	Positive LVDS differential data input (Odd data)
5	RxOIN2	Negative LVDS differential data input (Odd data, H-Sync, V-Sync, DSPTMG)
6	RxOIN2+	Positive LVDS differential data input (Odd data, H-Sync, V-Sync, DSPTMG)
7	VSS	Power Ground
8	RxOCLKIN-	Negative LVDS differential clock input (Odd clock)
9	RxOCLKIN+	Positive LVDS differential clock input (Odd clock)
10	RxOIN3	Negative LVDS differential data input (Odd data)
11	RxOIN3+	Positive LVDS differential data input (Odd data)
12	RxEIN0	Negative LVDS differential data input (Even data)
13	RxEIN0+	Positive LVDS differential data input (Even data)
14	VSS	Power Ground
15	RxEIN1	Negative LVDS differential data input (Even data)
16	RxEIN1+	Positive LVDS differential data input (Even data)
17	VSS	Power Ground
18	RxEIN2	Negative LVDS differential data input (Even data)
19	RxEIN2+	Positive LVDS differential data input (Even data)
20	RxECLKIN-	Negative LVDS differential clock input (Even clock)
21	RxECLKIN+	Positive LVDS differential clock input (Even clock)
22	RxEIN3	Negative LVDS differential data input (Even data)
23	RxEIN3+	Positive LVDS differential data input (Even data)
24	VSS	Power Ground
25	VSS	Power Ground
26	NC	No Connection (for AUO test)
27	VSS	Power Ground
28	VCC	+5.0V Power Supply
29	VCC	+5.0V Power Supply
30	VCC	+5.0V Power Supply

Note1: Start from left side

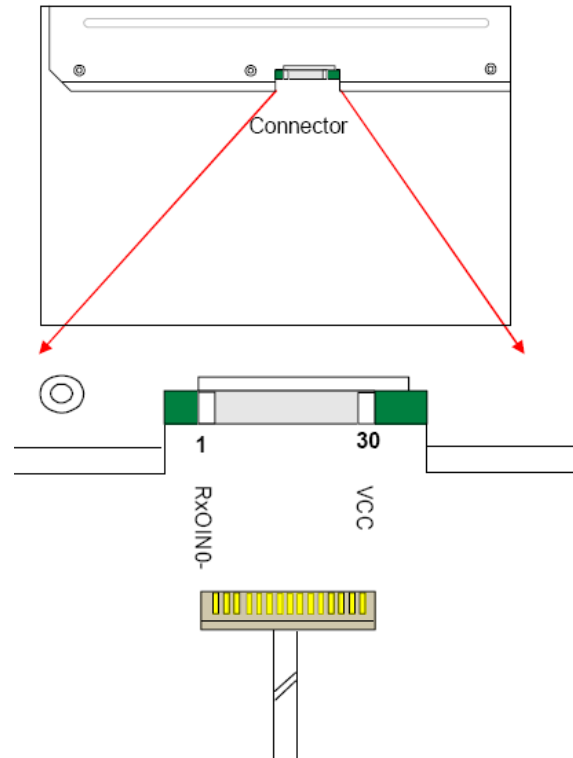

Note2: Input signals of odd and even clock shall be the same timing. Note3: Please follow PSWG.

Interface Timing

Timing Characteristics

Item	Symbol	Min	Typ	Max	Unit	
Data CLK	Tclk	40	54	67.5	MHz	
H-section	Period	Th	680	844	1024	Tclk
	Display Area	Tdisp(h)	640	640	640	Tclk
V-section	Period	Tv	1028	1066	2048	Th
	Display Area	Tdisp(v)	1024	1024	1024	Th
Frame Rate	F	50	60	75	Hz	

Note : DE mode only

Timing Diagram

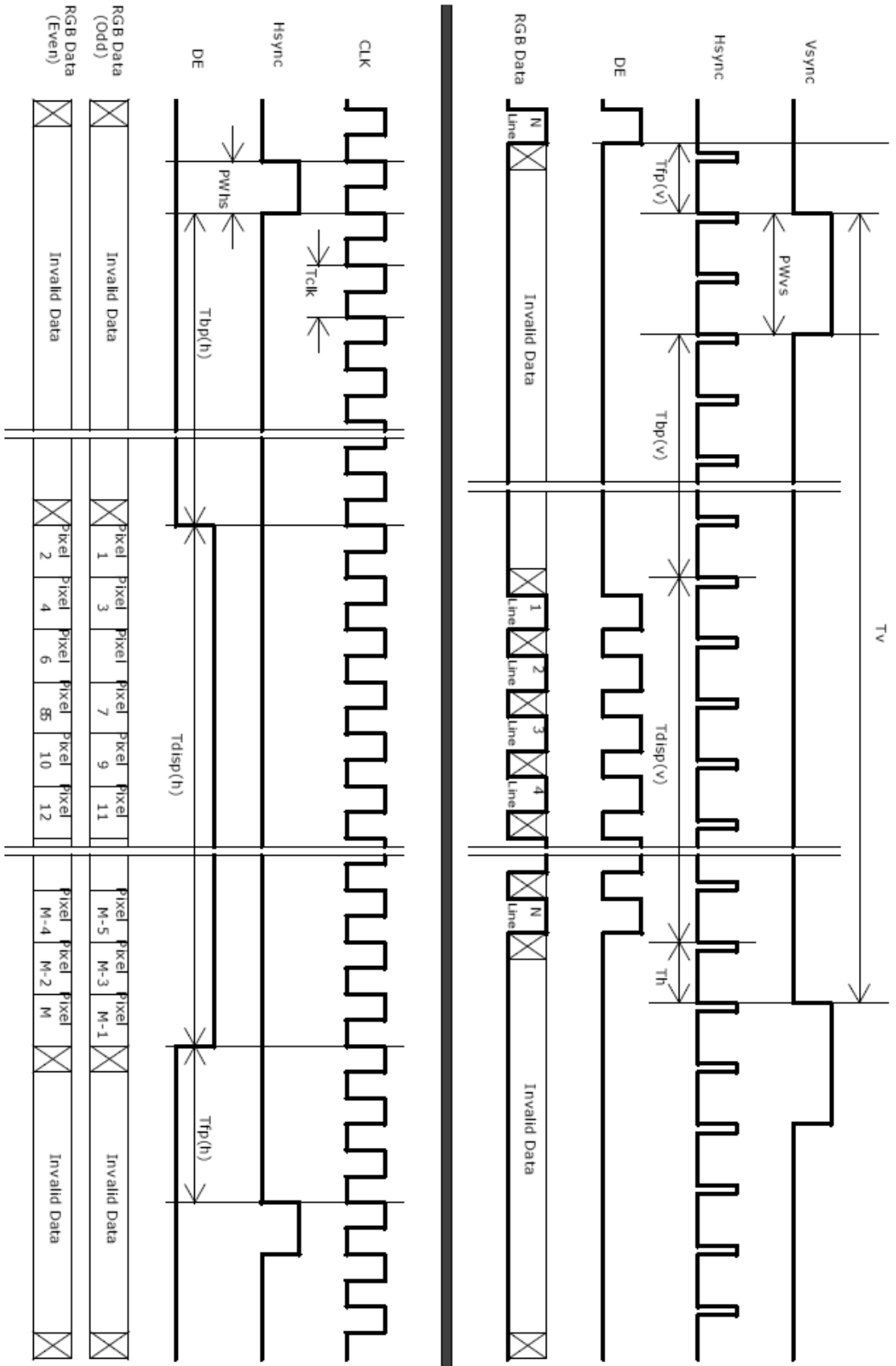

Power ON/OFF Sequence

VDD power and lamp on/off sequence is as follows. Interface signals are also shown in the chart. Signals from any system shall be Hi-Z state or low level when VDD is off.

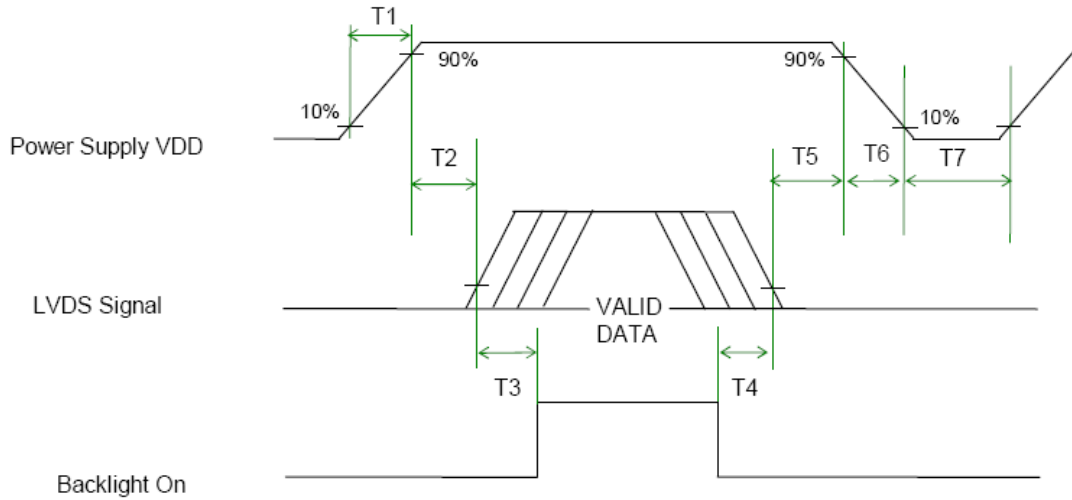

Power Sequence Timing

Parameter	Value			Unit
	Min.	Typ.	Max.	
T1	0.5	-	10	[ms]
T2	0	-	50	[ms]
T3	200	-	-	[ms]
T4	200	-	-	[ms]
T5	0	16	50	[ms]
T6	-	-	10	[ms]
T7	500	-	-	[ms]

Note: The values of the table are follow PSWG.

Connector & Pin Assignment

Physical interface is described as for the connector on module. These connectors are capable of accommodating the following signals and will be following components.

TFT LCD Module

Connector

Connector Name / Designation	Interface Connector / Interface card
Manufacturer	JST or compatible
Type Part Number	FI-XB30SSL-HF15
Mating Housing Part Number	FI-X30HL

Pin Assignment

Pin#	Signal Name	Pin#	Signal Name
1	RxOIN0	2	RxOIN0+
3	RxOIN1	4	RxOIN1+
5	RxOIN2	6	RxOIN2+
7	VSS	8	RxOCLKIN-
9	RxOCLKIN+	10	RxOIN3-
11	RxOIN3+	12	RxEIN0-
13	RxEIN0+	14	VSS
15	RxEIN1	16	RxEIN1+
17	VSS	18	RxEIN2-
19	RxEIN2+	20	RxECLKIN-
21	RxECLKIN+	22	RxEIN3-
23	RxEIN3+	24	VSS
25	VSS	26	NC
27	VSS	28	VCC
29	VCC	30	VCC

Backlight Unit

Physical interface is described as for the connector on module. These connectors are capable of accommodating the following signals and will be following components.

Connector Name / Designation	Lamp Connector / LED Backlight lamp
Manufacturer	JST
Type Part Number	EHR-2 or Compatible
Mating Type Part Number	S2B-EH or Compatible

Signal for LED Backlight connector

Connector No.	Pin No.	Input	Color	Function
CN1	1	Vcc	RED	Positive pole
	2	Gnd	Black	Negative pole
CN2	1	Vcc	RED	Positive pole
	2	Gnd	Black	Negative pole

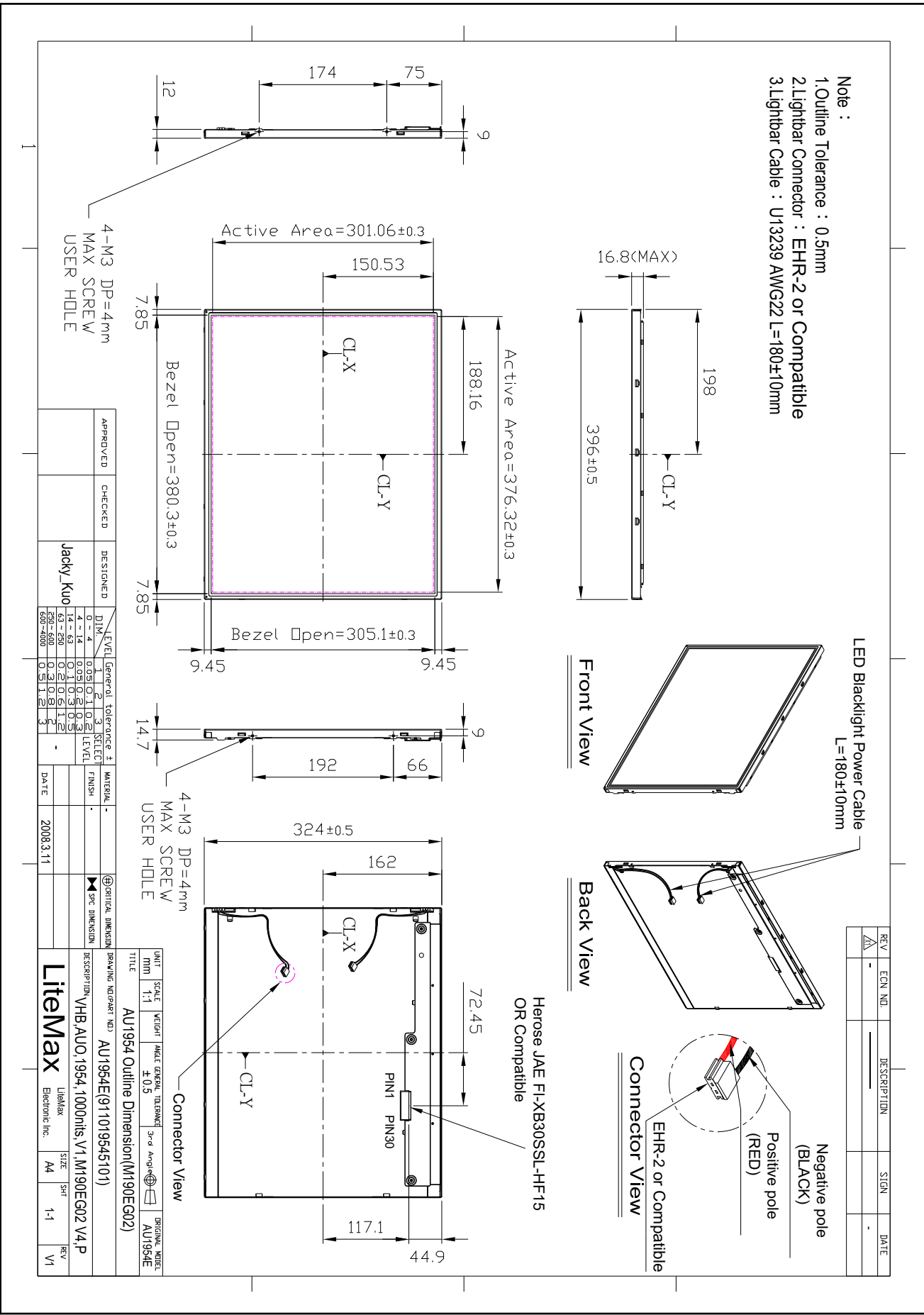

APPROVED	CHECKED	DESIGNED	LEVEL	General tolerance ±	SELECT	MATERIAL	FINISH	DATE
		Jacky_Kuo	0-4	0.05	1			2008.3.11
			4-14	0.1	2			
			14-63	0.15	3			
			63-250	0.2	4			
			250-600	0.3	5			
			600-1000	0.5	6			

UNIT	SCALE	WEIGHT	ANGLE GENERAL TOLERANCE	3rd Angle	ORIGINAL MODEL
MM	1:1		±0.5		AU1954E

TITLE
AU1954 Outline Dimension(M190EG02)

DESCRIPTION
VHB_AU0_1954_1000nits_V1_M190EG02 V4/P

LibMax
Electronic Inc.

SIZE	SHT	REV
A4	1-1	V1

REV	ECON NID	DESCRIPTION	SIGN	DATE
-				